

CM0805D900R-10

UNCONTROLLED DOCUMENT

PHYSICAL DIMENSIONS:

A	2.00 [.079]	+ 0.20 [.008]
B	1.20 [.047]	+ 0.20 [.008]
C	1.20 [.047]	+ 0.20 [.008]
D	0.15 [.006]	+ 0.10 [.004]
T1	0.55 [.022]	+ 0.10 [.004]
T2	0.46 [.018]	+ 0.10 [.004]

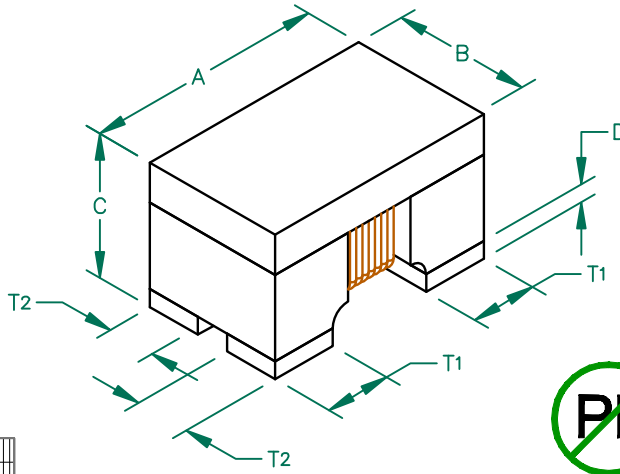

Electrical Characteristics		Nominal	Min	Max
Common Mode Impedance @ 100MHz	(Ω)	90	67.5	112.5
DCR	(Ω)	-	-	0.3
Rated Current	(mA)	-	-	400

- NOTES: UNLESS OTHERWISE SPECIFIED
1. TAPED AND REELED per CURRENT EIA SPECIFICATIONS 7" REELS, EMBOSSED PLASTIC TAPE 2,000 PCS/REEL.
 2. TERMINATION FINISH 100% MATTE TIN.
 3. COMPONENTS SHOULD BE ADEQUATELY PREHEATED BEFORE SOLDERING.

Z, R, XL vs. FREQUENCY

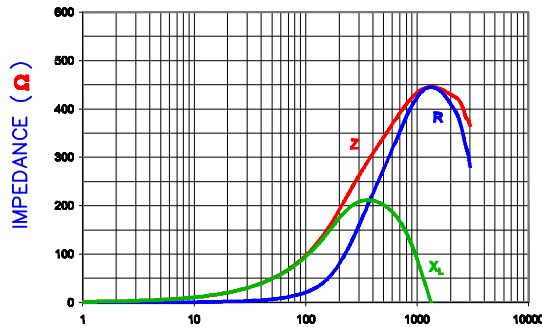

FREQUENCY (MHz)

Z R XL

Z vs. FREQUENCY (C,N,O)

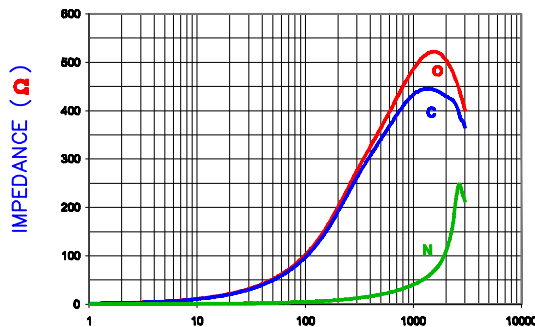

FREQUENCY (MHz)

Open Common Normal

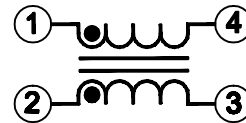

LAND PATTERNS FOR REFLOW SOLDERING

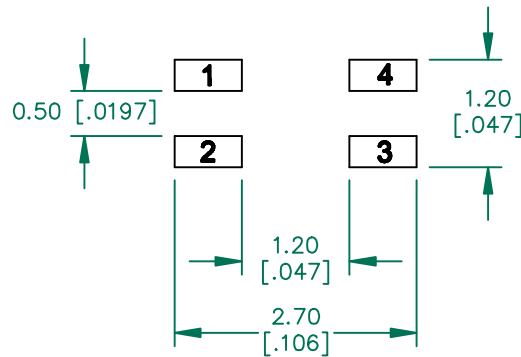

RECOMMENDED SOLDERING CONDITIONS

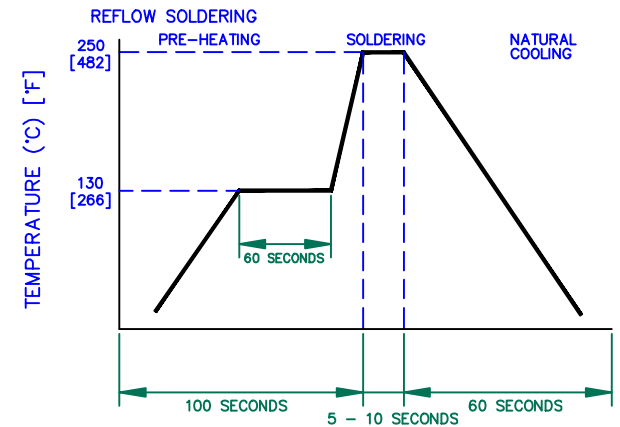

DIMENSIONS ARE IN mm [INCHES].				This print is the property of Laird Tech. and is loaned in confidence subject to return upon request and with the understanding that no copies shall be made without the written consent of Laird Tech. All rights to design or invention are reserved.			
PROJECT/PART NUMBER:	REV	PART TYPE:	DRAWN BY:				
C UPDATE COMPANY LOGO 04/28/09 JRK	C	CM CHOKE	JRK				
B UPDATE COMPANY LOGO 05/14/07 JRK	DATE:	SCALE:	SHEET:				
A ORIGINAL DRAFT 08/11/06 JRK	08/11/06	NTS					
REV DESCRIPTION DATE INT	CAD #	TOOL #					
				CM0805D900R-10			2 of 2