

PHYSICAL DIMENSIONS:

A	12.57	[.495]	± 0.20	[.008]
B	5.72	[.225]	± 0.10	[.004]
B ₁	6.73	[.265]	MAX	
C	4.32	[.170]	± 0.08	[.003]
C ₁	5.00	[.197]	MAX	
D	2.41	[.095]	± 0.08	[.003]
E	0.89	[.035]	± 0.13	[.005]
E ₁	1.91	[.075]	± 0.13	[.005]

WIRE:

T ₁	1.91	[.075]	± 0.25	[.010]
T ₂	0.38	[.015]	TYP.	
T ₃	0.38	[.015]	TYP.	

CM5022R800R-10

UNCONTROLLED DOCUMENT

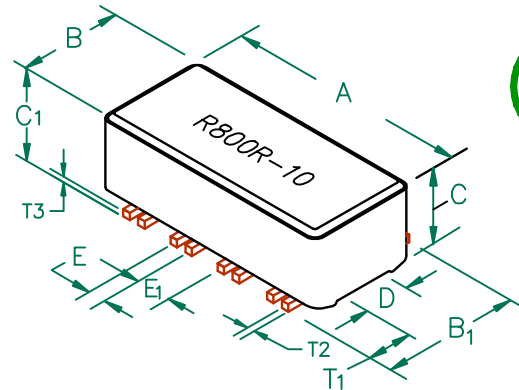

ELECTRICAL CHARACTERISTICS:

Z @ 100MHz (Ω)	DCR (Ω)	Rated Current
Nominal	80	
Minimum	64	
Maximum	-	0.02
		5,000 mA

NOTES: UNLESS OTHERWISE SPECIFIED

1. TAPED AND REELED per CURRENT EIA SPECIFICATIONS 13" REELS, 1000 PCS PER REEL.
2. COMPONENTS SHOULD BE ADEQUATELY PREHEATED BEFORE SOLDERING.
3. REF. CARRIER TAPE SPECIFICATION # CART5022-0P.
4. TERMINATION FINISH IS 100% TIN.
5. THIS PART HAS NO PIN POLARITY.

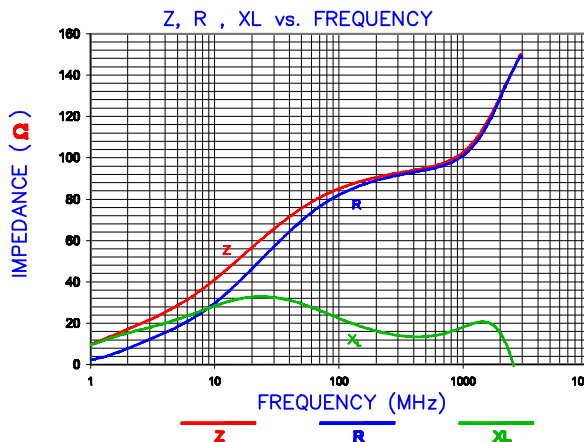
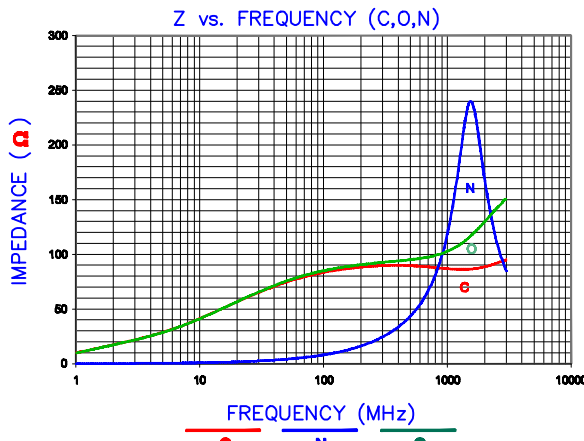

LAND PATTERNS FOR REFLOW SOLDERING

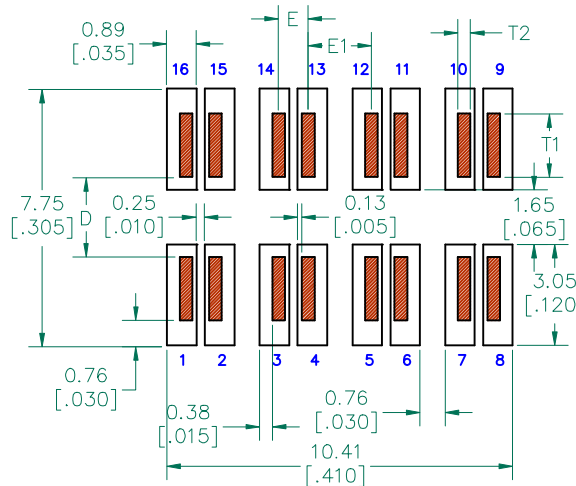

EQUIVALENT CIRCUIT NO POLARITY

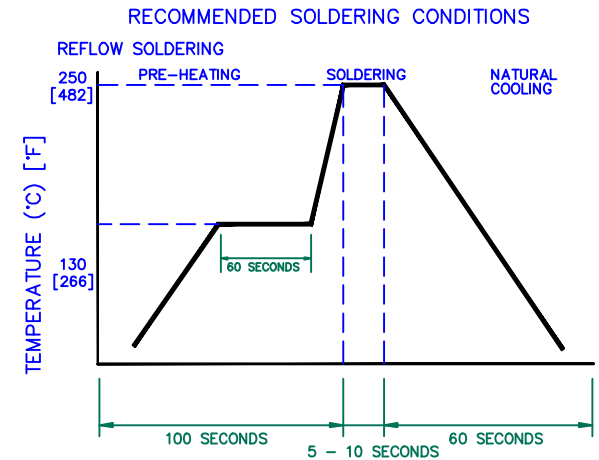
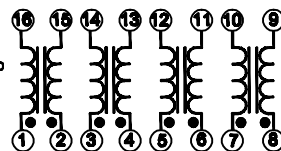

DIMENSIONS ARE IN mm (INCHES).				This print is the property of Laird Tech. and is loaned in confidence subject to return upon request and with the understanding that no copies shall be made without the written consent of Laird Tech. All rights to design or invention are reserved.			
C	UPDATE COMPANY LOGO ADD EQUIVALENT CIRCUIT	02/03/09	JRK	PROJECT/PART NUMBER:	CM5022R800R-10	REV	C
B	UPDATE COMPANY LOGO	12/19/07	JRK	DATE:	08/02/04	SCALE:	NTS
A	ORIGINAL DRAFT	08/02/04	JRK	CAD #		SHEET:	
REV	DESCRIPTION	DATE	INT		CM5022R800R-10-C-2	TOOL #	H0495-0
						DRAWN BY: JRK	
						PART TYPE: ASSEMBLY	
						SHEET: 2 of 3	

